

# Installation Guide

## Illuminated Image Ceiling Fixture MRI Compatible



### Important Safety Instructions

When using electrical equipment, basic safety precautions should always be followed including the following:

#### Read And Follow All Safety Instructions

1. **Warning:** This luminaire must be installed in accordance with the NEC or your local electrical code. If you are not familiar with these codes and requirements, consult a qualified electrician. *Attention: Ce luminaire doit être installé conformément au NEC ou à votre code électrique local. Si vous n'êtes pas familier avec ces codes et exigences, consultez un électricien qualifié.*
2. **Warning:** This equipment is not for use in hazardous combustible atmospheres as defined by the National Electrical Code. *Avertissement: Cet équipement ne doit pas être utilisé dans des atmosphères combustibles dangereuses telles que définies par le National Electrical Code.*
3. **Danger:** Risk of shock - Disconnect power before installation. *Danger: Risque de choc – Couper l'alimentation avant l'installation.*
4. Do not install insulation within 76 mm (3 in) of any part of this luminaire. *Ne pas mettre l'isolant a moins de 76 mm (3 po.) De toute partie du luminaire.*
5. Dry locations only. *Pour emplacements secs seulement.*
6. Inherently protected. *Protection inherente.*
7. This luminaire must be mounted or supported independently of an outlet box. *Ce luminaire ne doit pas être monté sur une boîte de sortie ni supporté par une telle boîte.*

### Save These Instructions For Future Reference

### Illuminated Image Ceiling Fixtures

1-07-000095 2'x2' Backlit Troffer

1-07-000102 2'x4' Backlit Troffer

\*Consult factory for custom sizes

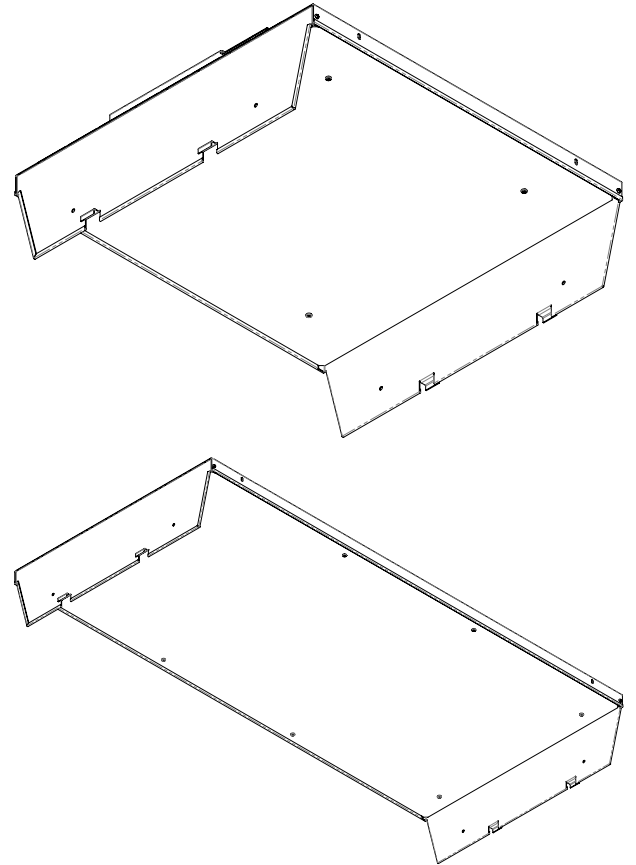

### Installation:

**Warning:** Fixtures should be supported independently of the ceiling grid. Ceiling structure should be installed to withstand a load rating of 4lbs/sqft. Ceiling mains at the Image Ceiling area to be run every 24in. and should be ran the shortest distance possible.

Diagram 1

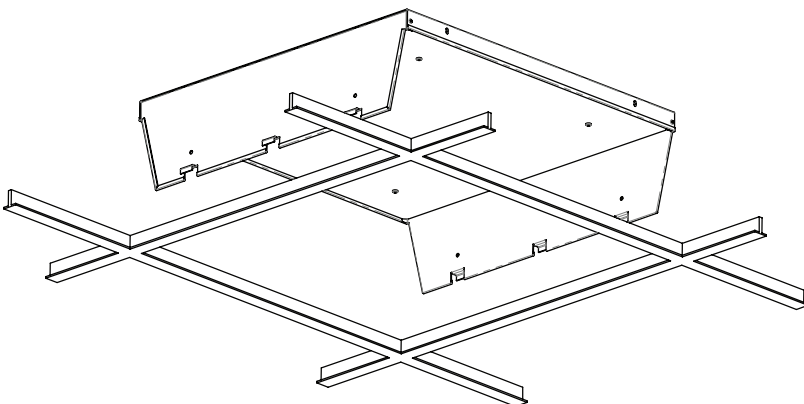

### Single 2'x2' Ceiling Fixture Installation

**NOTE:** There are multiple configurations possible for the Illuminated Image Ceiling Fixtures. Illustrated below is an example of a standard 2'x2' fixture installation. Questions or concerns with a specific installation should be directed to the Customer Site Installation drawings unique to the job site or to your Sales Representative.

**Step 1:**  
Turn off the power supply.

**Step 2:**  
Slide the Ceiling Fixture Frame into the existing ceiling at an angle.

**Step 3:**  
Place frame on to the ceiling grid allowing the tabs on each edge to support the frame as shown in **Diagram 2**.

Diagram 2

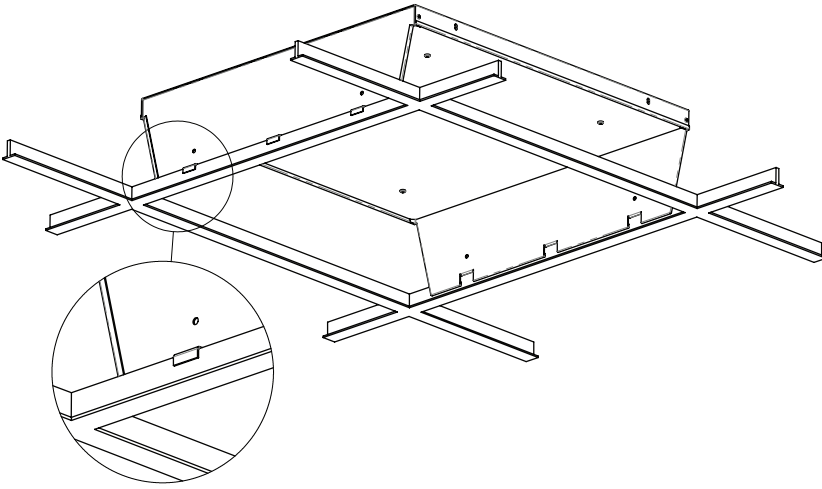

**Warning:**

Fixtures should be supported independently of the ceiling grid. Ceiling structure should be installed to withstand a load rating of 4lbs/sqft. Ceiling mains at the Image Ceiling area to be run every 24in. and should be ran the shortest distance possible.

**Step 4:**

Using 12 AWG wire hanger, suspend the luminaire to the building frame or structural members by the mounting tabs located on the recessed surface. **Note:** Ensure the luminaire is level and only resting on the ceiling grid. The majority of the weight of the luminaire should be supported by the wire hangers. See **Diagrams 3 and 4.**

**Step 5:**

Wire the luminaire per the **Electrical Connections** section.

Diagram 3

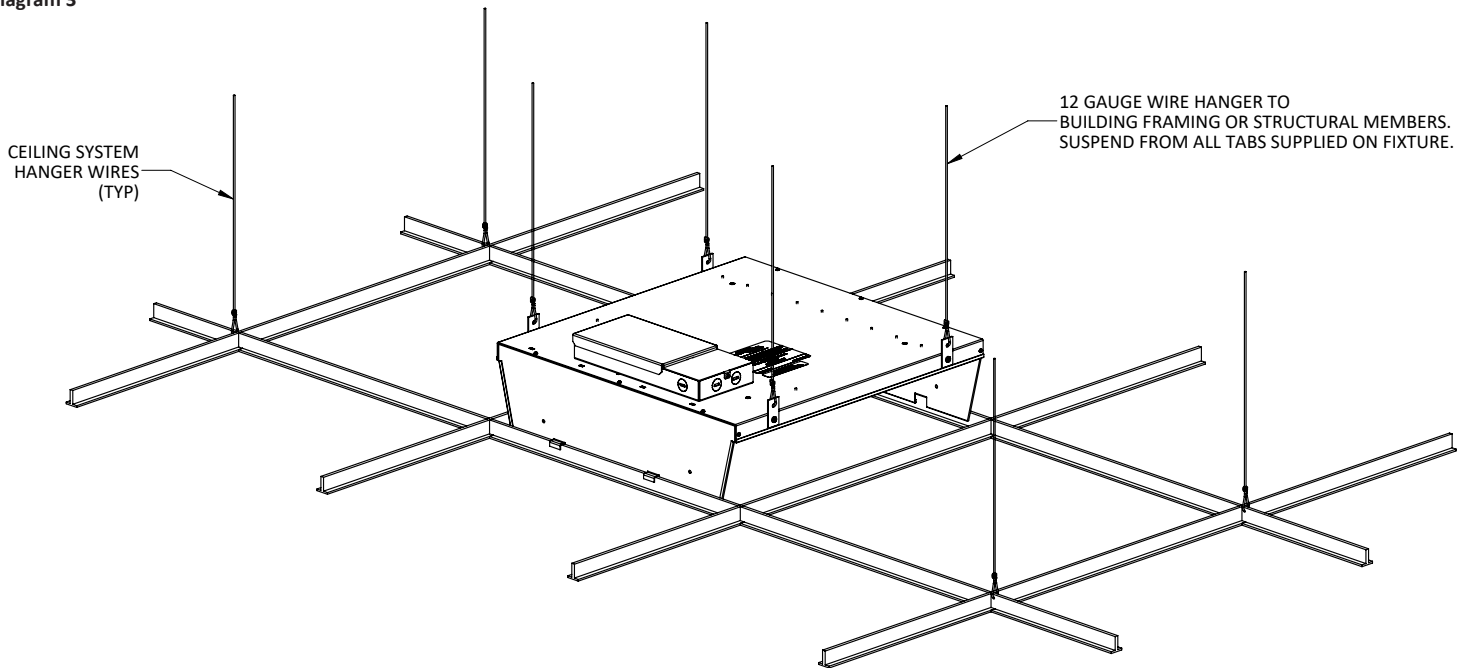

Diagram 4

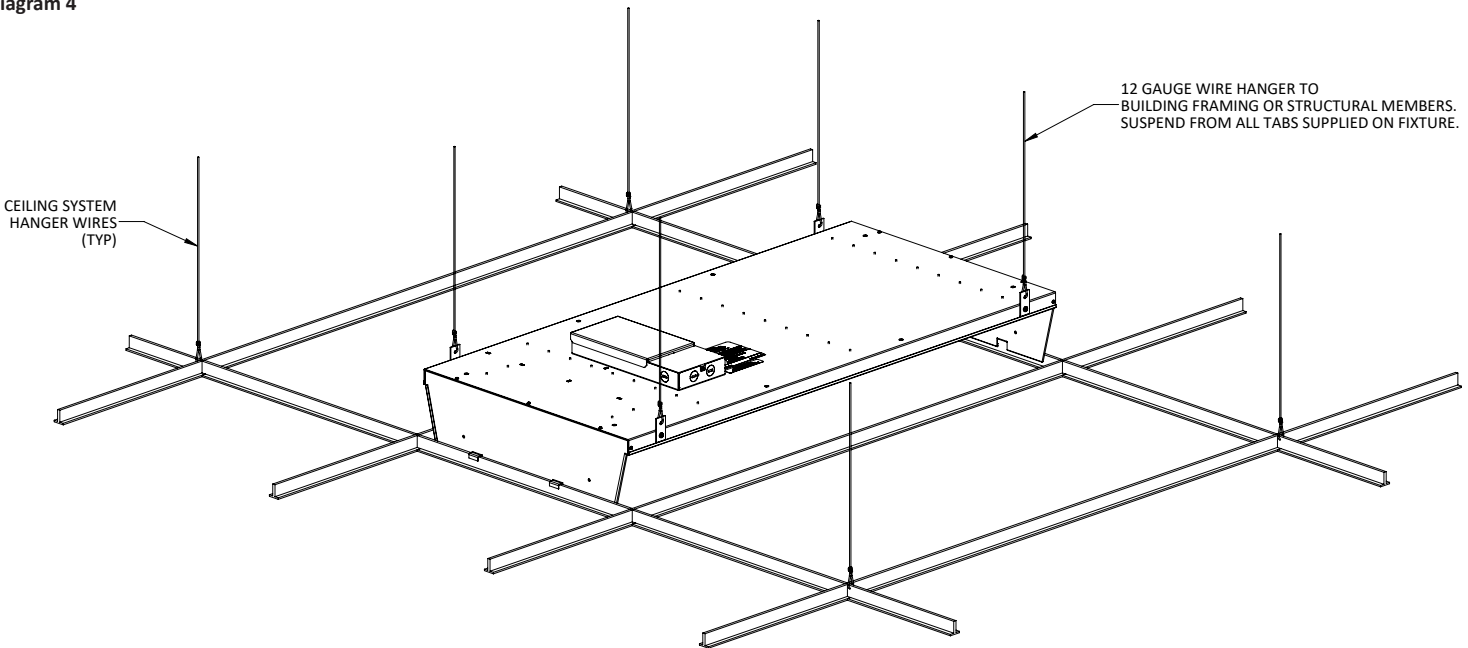
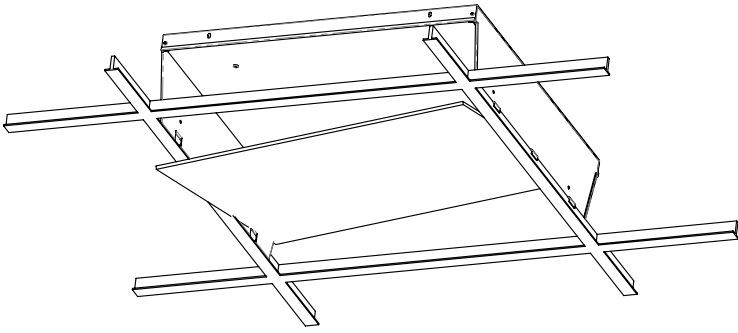

Diagram 5



**Step 6:**

To install the decorative image, slide the lens into the installed frame as shown in **Diagram 5**.

**Step 7:**

Turn on the power supply.

**Custom Configurations**

**NOTE:** For custom shaped ceilings, screw lags may be supplied or mounting holes will be provided for mounting directly to the intended mounting surface. Questions or concerns with a specific installation should be directed to the Customer Site Installation drawings unique to the job site or to your Sales Representative.

Diagram 6

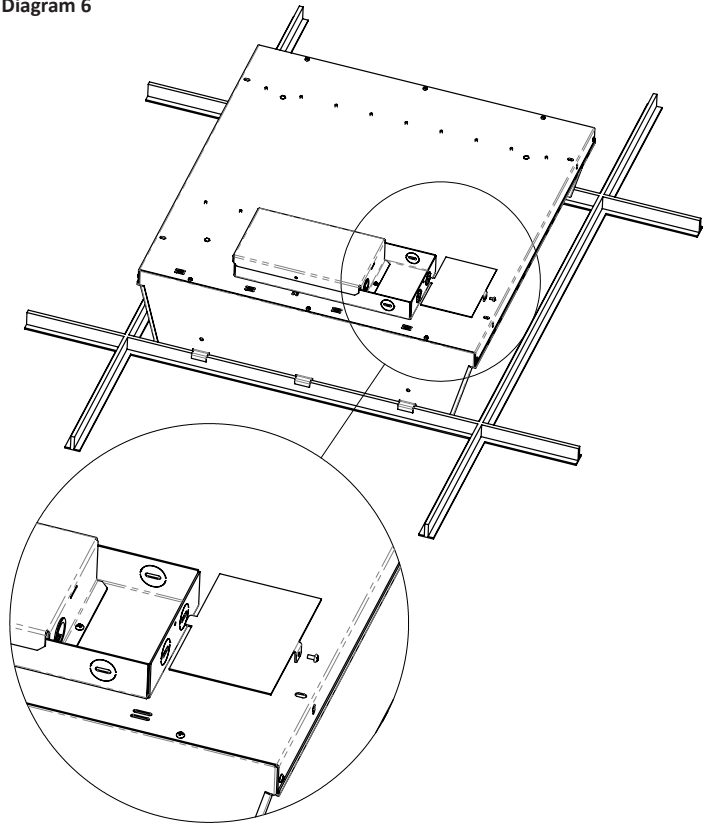

**Electrical Connections**

**Step 1:**

Remove the Junction Box cover as shown in **Diagram 6**.

**Step 2:**

Using 90°C minimum rated wire connectors, terminate the supply wiring through the Junction Box.

**DC WHITE LIGHT WIRING - Diagram 7**

Connect + 12 VDC supply lead to the **RED** positive lead.  
Connect - 12 supply lead to the **BLACK** negative lead.

Diagram 7

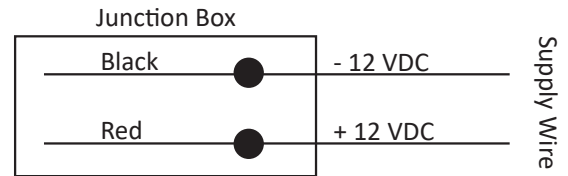

**Directive 2012/19/EU (WEEE - Waste Electrical and Electronic Equipment): Information for Users**

This product complies with EU Directive 2012/19/EU. The crossed out wheeled bin symbol on the article means that at the end of its useful lifespan, this product must not be disposed of with your other household or municipal waste. This product has required the extraction and use of natural resources for its production. It may contain hazardous substances that could impact health and the environment if not properly disposed. In order to avoid dissemination of those substances in our environment and to diminish the pressure on the natural resources, the user is responsible for delivering the appliance to an appropriate collection facility at the end of its useful lifespan. The separate collection and recycling of your waste equipment at the time of disposal will help conserve natural resources and ensure that it is recycled in a manner that protects human health and the environment. For more information on available collection facilities contact your local waste collection service or the place of purchase.